

USER MANUAL

TVL SERIES



Read the user's manual carefully before starting to use the unit or software.
Producer reserves the right to implement changes without prior notice.

Explanation of symbols used in the manual



This symbol denotes especially important guidelines concerning the installation and operation of the device. Not complying with the guidelines denoted by this symbol may cause an accident, damage or equipment destruction.

IF THE DEVICE IS NOT USED ACCORDING TO THE MANUAL THE USER IS RESPONSIBLE FOR POSSIBLE DAMAGES.



This symbol denotes especially important characteristics of the unit. Read any information regarding this symbol carefully.

1. BASIC REQUIREMENTS AND USER SAFETY

- Do not use the unit in areas threatened with excessive shocks, vibrations, dust, humidity, corrosive gasses and oils.



- Do not use the unit in areas where there is risk of explosions.
- Do not use the unit in areas with significant temperature variations, exposure to condensation or ice.
- Do not use the unit in areas exposed to direct sunlight.
- Make sure that the ambient temperature (e.g. inside the control box) does not exceed the recommended values. In such cases forced cooling of the unit must be considered (e.g. by using a ventilator).

- The manufacturer is not responsible for any damages caused by inappropriate installation, not maintaining the proper environmental conditions and using the unit contrary to its assignment.
- Installation should be conducted by qualified personnel. During installation all available safety requirements should be considered. The fitter is responsible for executing the installation according to this manual, local safety and EMC regulations.

- GND input of device should be connected to PE wire;



- The unit must be properly set-up, according to the application. Incorrect configuration can cause defective operation, which can lead to unit damage or an accident. If in the case of a unit malfunction there is a risk of a serious threat to the safety of people or property additional, independent systems and solutions to prevent such a threat must be used.
- The unit uses dangerous voltage that can cause a lethal accident. The unit must be switched off and disconnected from the power supply prior to starting installation of troubleshooting (in the case of malfunction).
- Neighboring and connected equipment must meet the appropriate standards and regulations concerning safety and be equipped with adequate overvoltage and interference filters.
- Do not attempt to disassemble, repair or modify the unit yourself. The unit has no user serviceable parts. Defective units must be disconnected and submitted for repairs at an authorized service center.



The unit is designed for operation in an industrial environment and must not be used in a household environment or similar.

2. GENERAL CHARACTERISTICS

The TruVu meter is equipped with one current input 0-20 / 4-20mA and one voltage input 0-5 / 1-5 / 0-10 / 2-10V. Current input has additionally overcurrent protection circuit, which protects standard resistor. The selection of active input is realized by software, and the selected input can be changed at any time. Additionally the TruVu allows user to select a conversion characteristic of several kinds: linear, square, square root, user defined (max.20 points length) and volume characteristics of a cylindrical tank in the vertical and horizontal position. Result is showed on 4-digit LED display. Displayed values range can be selected by user, from -999 to 9999, plus decimal point.

The device can be equipped with two relay (or OC type) outputs. Device TruVu is equipped with RS-485 / Modbus RTU communication interface and sensor supply output. The meter can be ordered in three power supply versions.

The device has 4 buttons being used for main presets programming. To get high protection level, the keyboard is mounted under a transparent cover. To allow user to change presets without opening the cover, an IR sensor is located on Front. Remote controller keyboard is equivalent to the device keyboard (Note, that remote controller is not a part of the TruVu set – it is an additional equipment).

The TruVu can be used for controlling and regulation of processes that require proportional and threshold control for example: Temperature, Level, Valve Control.

3. TECHNICAL DATA

Power supply voltage (depending on version)	230V AC \pm 10%, 50 \div 60 Hz (separated) or 110V AC \pm 5%, 50 \div 60 Hz (Standard) or 24V AC \pm 5%, 50 \div 60 Hz (separated) or 24V DC \pm 15%, (not separated)
External fuse (required)	T - type, max. 2 A
Power consumption	2max. 2.6 VA @ 230V AC and @ 110V A max. 4.5 W @ 24V DC
Current input	0 \div 20 mA, 4 \div 20 mA overload protected, maximum input current about 40 mA
Current measurement accuracy	\pm 0,1% @ 25°C; \pm one digit (for 0 \div 20 mA range)
Current input resistance	< 65 W (typical 55 W)
Voltage input	0 \div 5 V, 1 \div 5 V, 0 \div 10 V, 2 \div 10 V
Voltage measurement accuracy	\pm 0,1% @ 25°C; \pm one digit (for 0 \div 10 V range)
Voltage input resistance	> 50 k Ω
Temperature stability	50 ppm / °C
Display range	-999 \div 9999, plus decimal point
Accepted prolonged input overload	20%

Outputs relay	0 or 2 NO, 1A/250V AC ($\cos\phi = 1$) or 4 NO
Sensor power supply U_o	not stabilized, not separated from measuring inputs, in 230V AC and 110V AC and 24V AC version: $U_o = 24V DC \pm 3V / \max. 25 mA$; in 24V DC version: $U_o = U_s / \max. 100 mA, R_o = 30 \Omega$ (where U_s - device power supply, R_o - internal resistance for sensor power supply output)
Communication interface	RS 485, 8N1 and 8N2, Modbus RTU, not separated
Baud rate	1200 bit/s ÷ 115200 bit/s
Display(dependent on version)	LED, 4 digit, 20mm height, red or LED, 4 digit, 20mm height, green
Data memory	Non-Volatile Memory, EEPROM type
Protection level	IP 65 NEMA 4X
Housing type Housing material	IP 65 NEMA 4X Poly Carbonate
without glands:	110 x 80 x 67 mm
with glands:	110 x 105 x 67 mm
Operating temperature (dependent on version)	-25°C to +50°C
Storage temperature (dependent on version)	-30°C to +70°C or -20°C to +70°C
Humidity	5 to 90% no condensation
Altitude	up to 2000 meters above sea level
Screws tightening max. torque	0,5 Nm
Max. connection leads diameter	2,5 mm ²
Safety requirements	According to: PN-EN 61010-1 installation category: II pollution degree: 2 voltage in relation to ground: 300V AC insulation resistance: >20M Ω insulation strength between power supply and input/output terminal: 1min. @ 2300V insulation strength between relays terminal: 1min. @ 1350V
EMC	according to: PN-EN 61326-1



This is a class A unit. In a residential or a similar area it can cause radio frequency interference. In such cases the user can be requested to use appropriate preventive measures.

4. DEVICE INSTALLATION

The unit has been designed and manufactured in a way assuring a high level of user safety and resistance to interference occurring in a typical industrial environment. In order to take full advantage of these characteristics installation of the unit must be conducted correctly and according to the local regulations.

- Read the basic safety requirements on page 3 prior to starting the installation.
- Ensure that the power supply network voltage corresponds to the nominal voltage stated on the unit's identification label.
- The load must correspond to the requirements listed in the technical data.
- All installation works must be conducted with a disconnected power supply.
- Protecting the power supply connections against unauthorized persons must be taken into consideration.

4.1. UNPACKING

After removing the unit from the protective packaging, check for transportation damage. Any transportation damage must be immediately reported to the carrier. Also, write down the unit serial number located on the housing and report the damage to the manufacturer.

Attached with the unit please find:

- User's Manual,

4.2. ASSEMBLY



- Disconnect the power supply prior to starting assembly.
- Check the connections are wired correctly prior to switching the unit on.



To install device on the wall, a pinholes should be made. Figure 4.1 presents dimensions of the device and distances between holes. The back side of the device has four mounting holes. This part of the case should be mounted to a wall by screws.

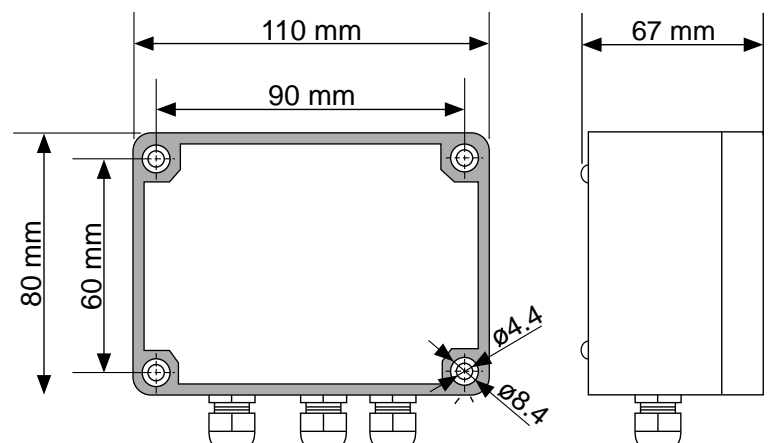

Figure 4.1. Device and assembly dimensions

INTRODUCTION

TECHNOLOGY

The Levelpro pressure transmitter is placed near or on the bottom of the tank. A ceramic pressure diaphragm within the pressure transmitter is exposed on one side to the application liquid.

The Levelpro transmitter measures the height of liquid above the position of the sensing diaphragm of the transmitter located inside the tank referenced to atmospheric pressure.

The transmitter consists of a ceramic piezo-resistive sensing element, encased in PVC, PVDF, PP, or 316 SS housing.

The Large diameter flush diaphragm is non-clogging and damage resistant to floating solids.

The Levelpro transmitter is equipped with a high tensile strength FEP (Teflon) shielded and vented cable. and contains an internal non-wetted weight and utilizes Kalrez o-ring seals The Ventilation tube in the cable automatically compensates for changes in atmospheric pressure above the tank.

1. GENERAL INFORMATION

1.1 Information on the operating manual

This operating manual contains important information on proper usage of the 100 series level sensing device. Read this operating manual carefully before installing and starting up the pressure measuring device.

Adhere to the safety notes and operating instructions which are given in this operating manual. Additionally applicable regulations regarding occupational safety, accident prevention as well as national installation standards and engineering rules must be complied with.

This operating manual is copyrighted. The contents of this operating manual reflect the version available at the time of printing. It has been issued to our best knowledge. Icon Process Controls is not liable for any incorrect statements or their corresponding effects.

1.2 Symbols Used

 **DANGER!** — dangerous situation, which may result in death or serious injuries

 **WARNING!** — potentially dangerous situation, which may result in death or serious injuries

 **WARNING!** — To avoid operator hazards and damages to the device, the following instructions have to be installed by qualified technical personnel.

NOTE : *tips and information to ensure a failure-free operation*

1.3 Limitation Of Liability

By non observance of the operating manual, inappropriate use, modification or damage, no liability is assumed and warranty claims will be excluded.

1.4 Intended Use

The Levelpro Level Sensors have been developed for continuous level measurement. It is the operator's responsibility to check and verify the suitability of the device for the intended application. If any doubts remain, please contact our technical department in order to ensure proper usage and compatibility. Icon Process Controls is not liable for any incorrect selections and their effects.

Permissible media are liquids (no solids or frozen media), specified in the data sheet. In addition it has to be ensured, that this medium is compatible with the any wetted parts of the level sensor or the associated cable.

The technical data listed in the current data sheet are engaging and must be complied with. If the data sheet is not available, please order or download it from our homepage. (<http://www.iconprocon.com>)

 **WARNING!** — Danger may result from improper usage!

4. ELECTRICAL INSTALLATION

⚠ WARNING! — Install the device only when the unit is not connected!

Establish the electrical connection of the device according to the technical data shown on the manufacturing label.

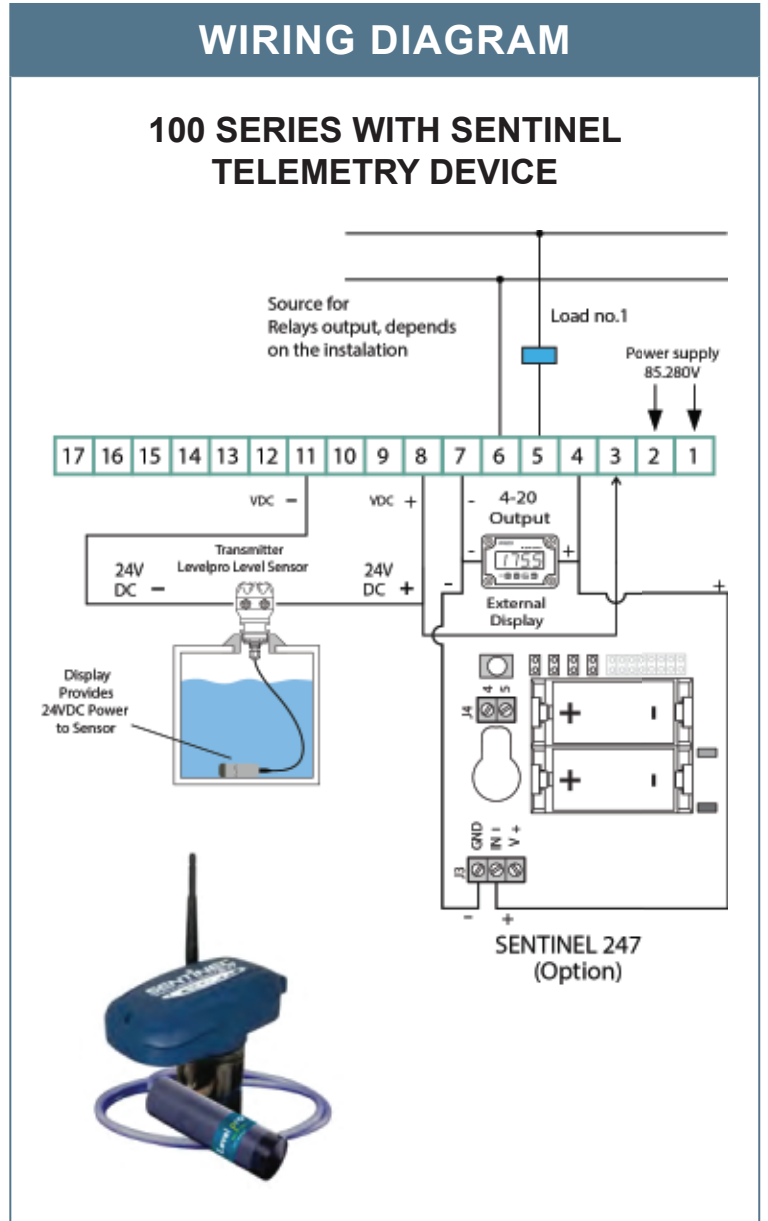
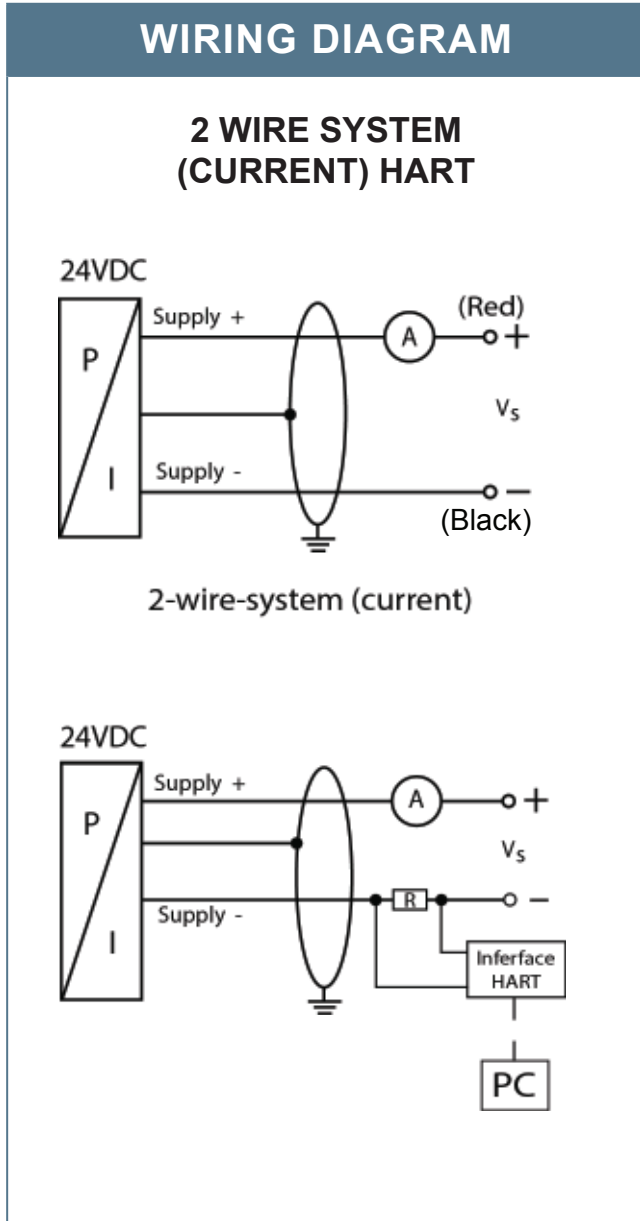

LP 100 SERIES TECHNICAL DATA

INSTALLATION AND OPERATING MANUAL

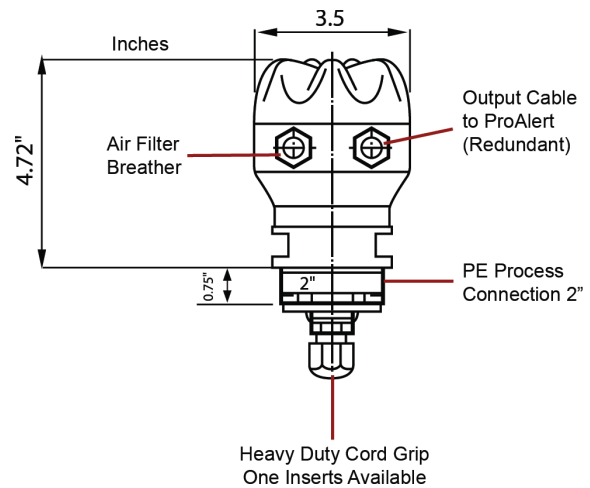
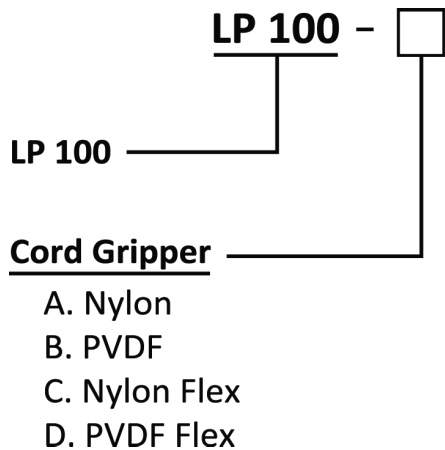
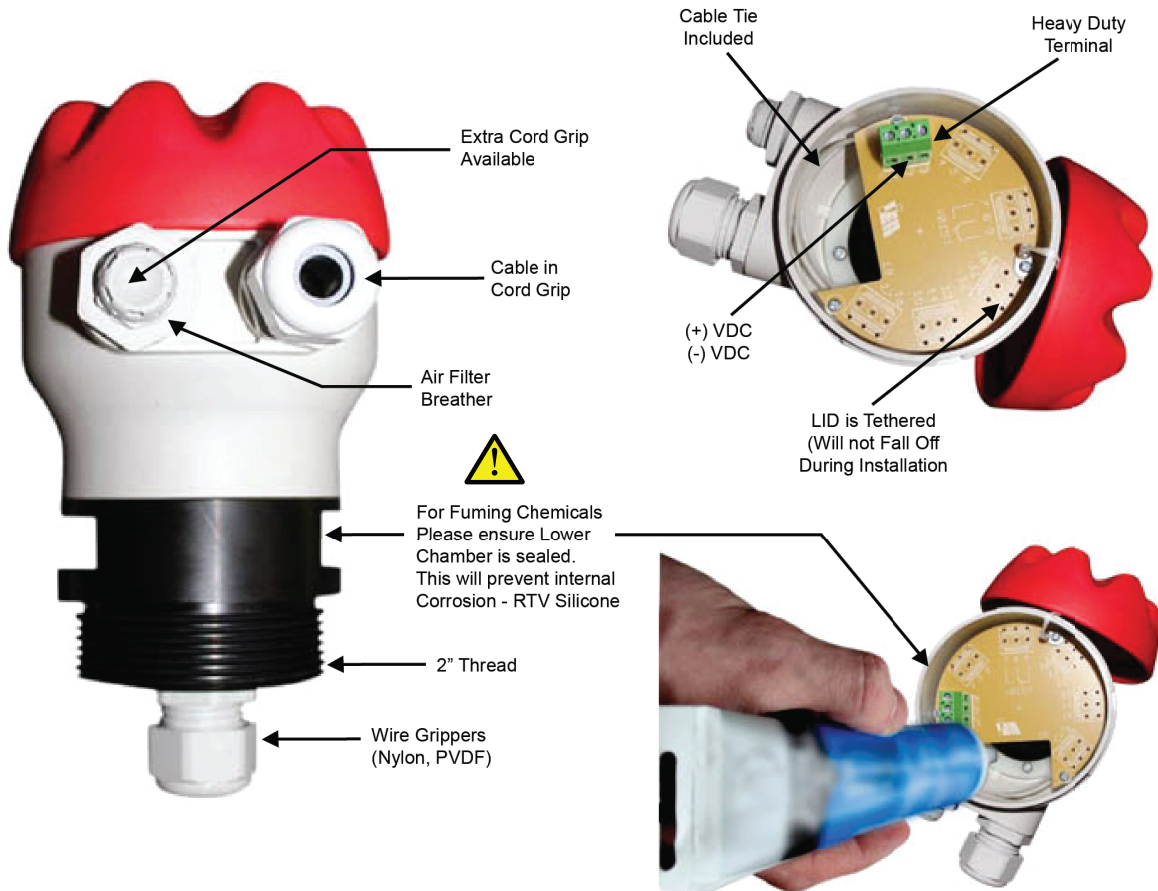

Contact Us for Assistance



For Fuming Chemicals please ensure Lower Chamber is sealed. This will prevent Internal Corrosion - RTV Silicone

MAINTENANCE

After final installation of the Levelpro transmitter and its companion display no routine maintenance is required. A periodic check of system calibration is suggested. Be sure to include a brief description of the problem plus any relevant application notes. Contact customer service to receive a return goods authorization number before shipping. Maintenance should consist of inspection to see that the transmitter is free from debris and not coated with any substance, which would prevent liquid from freely entering and leaving the transmitter. If this occurs, the transmitter should be cleaned.

INTRODUCTION

TECHNOLOGY

The Levelpro pressure transmitter is placed near or on the bottom of the tank. A ceramic pressure diaphragm within the pressure transmitter is exposed on one side to the application liquid.

The Levelpro transmitter measures the height of liquid above the position of the sensing diaphragm of the transmitter located inside the tank referenced to atmospheric pressure.

The transmitter consists of a ceramic piezo-resistive sensing element, encased in PVC, PVDF, PP, or 316 SS housing.

The Large diameter flush diaphragm is non-clogging and damage resistant to floating solids.

The Levelpro transmitter is equipped with a high tensile strength FEP (Teflon) shielded and vented cable. and contains an internal non-wetted weight and utilizes Kalrez o-ring seals The Ventilation tube in the cable automatically compensates for changes in atmospheric pressure above the tank.

Testing the Transmitter

1. First, verify that the sensor is wired correctly.
2. Next, check if the power supply is providing the required power.
3. Finally confirm that the loop resistance is not exceeding the sensor's specification.

If transmitter is not functioning properly, isolate the transmitter from the system and wire as shown in the figure.

Be sure to remove the sensor from the classified area when performing this test. Multi Meter should read 4mA with the transmitter out of liquid.

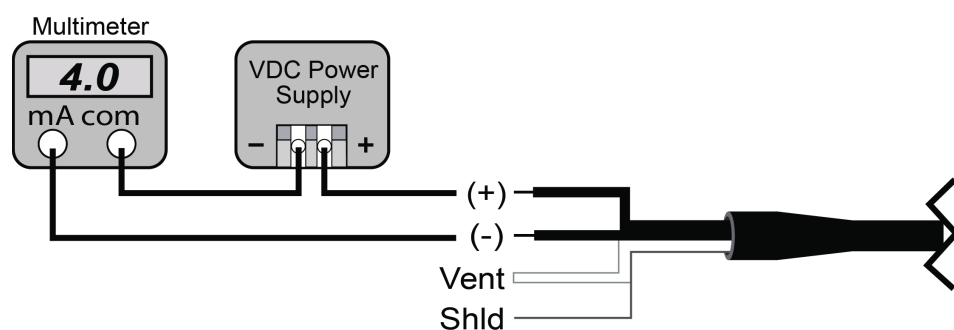

WARRANTY, RETURNS & LIMITATIONS

Icon Process Controls warrants to the original purchaser of its products that such products will be free from defects in materials and workmanship under normal use and service in accordance with instructions furnished by Icon Process Controls for a period of one year from the date of sale of such products. Icon Process Controls obligation under this warranty is solely and exclusively limited to the repair or replacement, at Icon's option, of the products or components, which Icon examination determines to its satisfaction to be defective in material or workmanship within the warranty period. Icon Process Controls must be notified within thirty (30) days pursuant to the instructions below of any claims of lack of conformity under this warranty. Any product repaired under this warranty will be warranted only for the remainder of the original warranty period. Any product provided as a replacement under this warranty will be warranted for the full 1 year from the date of sale.

RETURNS

Products cannot be returned to Icon Process Controls without Icon's prior authorization. To return a product that is thought to be defective please submit a customer return (MRA) request form and follow the instructions therein. All warranty and non-warranty product returns to Icon Process Controls must be shipped prepaid and insured. Icon will not be responsible for any products lost or damaged in shipment.

LIMITATIONS

This warranty does not apply to products which:

1. Are beyond the warranty period or are products for which the original purchaser does not follow the warranty procedures outlined above;
2. Have been subjected to electrical, mechanical or chemical damage due to improper, accidental or negligent use;
3. Have been modified or altered.
4. Anyone other than service personnel authorized by Icon have attempted to repair;
5. Have been involved in accidents or natural disasters; or
6. Are damaged during return shipment to Icon.

Icon Process Controls reserves the right to unilaterally waive this warranty and dispose of any product returned to Icon where:

1. there is evidence of a potentially hazardous material present with the product; or
2. the product has remained unclaimed at Levelpro for more than 30 days after Icon Process Controls has dutifully requested disposition. This warranty contains the sole express warranty made by Levelpro in connection with its products. ALL IMPLIED WARRANTIES, INCLUDING WITHOUT LIMITATION, THE WARRANTIES OF MERCHANTABILITY AND FITNESS FOR A PARTICULAR PURPOSE, ARE EXPRESSLY DISCLAIMED. The remedies of repair or replacement as stated above are the exclusive remedies for the breach of this warranty. IN NO EVENT SHALL Icon Process Controls BE LIABLE FOR ANY INCIDENTAL OR CONSEQUENTIAL DAMAGES OF ANY KIND INCLUDING PERSONAL OR REAL PROPERTY OF FOR INJURY TO ANY PERSON. THIS WARRANTY CONSTITUTES THE FINAL, COMPLETE AND EXCLUSIVE STATEMENT OF WARRANTY TERMS AND NO PERSON IS AUTHORIZED TO MAKE ANY OTHER WARRANTIES OR REPRESENTATIONS ON BEHALF OF Icon Process Controls.

4.3. CONNECTION METHOD



Due to possible significant interference in industrial installations appropriate measures assuring correct operation of the unit must be applied. To avoid the unit of

- Installation should be conducted by qualified personnel . During installation all available safety requirements should be considered. The fitter is responsible for executing the installation according to this manual, local safety and Federal regulations.
- The unit is not equipped with an internal fuse or power supply circuit breaker. Because of this an external time-delay cut-out fuse with a small nominal current value must be used (recommended bipolar, max. 2A) and a power supply circuitbreaker located near the unit. In the case of using a monopolar fuse it must be mounted on the phase cable (L).
- The power supply network cable diameter must be selected in such a way that in the case of a short circuit of the cable from the side of the unit the cable shall be protected against destruction with an electrical installation fuse.
- Wiring must meet appropriate standards and local regulations and laws.
- In order to secure against accidental short circuit the connection cables must be terminated with appropriate insulated cable tips.
- Tighten the clamping screws. The recommended tightening torque is 0.5 Nm. Loose screws can cause fire or defective operation. Over tightening can lead to damaging the connections inside the units and breaking the thread.
- In the case of the unit being fitted with separable clamps they should be inserted into appropriate connectors in the unit, even if they are not used for any connections.
- Unused terminals (marked as n.c.) must not be used for connecting any connecting cables (e.g. as bridges), because this can cause damage to the equipment or electric shock.
- If the unit is equipped with housing, covers and sealing to, protecting against water intrusion, pay special attention to their correct tightening or clamping. In the case of any doubt consider using additional preventive measures (covers, roofing, seals, etc.). Carelessly executed assembly can increase the risk of electric shock
- After the installation is completed do not touch the unit's connections when it is switched on, because it carries the risk of electrical shock.

Due to possible significant interference in industrial installations appropriate measures assuring correct operation of the unit must be applied. To avoid the unit of improper indications keep recommendations listed below.

- Avoid running signal cables and transmission cables together with power supply cables and cables controlling inductive loads (e.g. contactors). Such cables should cross at a right angle.
- Contactor coils and inductive loads should be equipped with interference protection systems, e.g. RC-type.
- Use of screened signal cables is recommended. Signal cable screens should be connected to the earth or ground only at one of the ends of the screened cable.
- In the case of magnetically induced interference the use of twisted pair of signal cables is recommended. Twisted pair (best if shielded) must be used with RS-485 serial transmission connections.
- In the case of measurement or control signals are longer than 100 Feet or go outside of the building then additional safety circuits are required.
- In the case of interference from the power supply side the use of appropriate interference filters is recommended. Bear in mind that the connection between the filter and the unit should be as short as possible and the metal housing of the filter must be connected to the earth with the largest possible surface. The cables connected to the filter output must

Connection of the power supply, and the measurement and controlling signals should be made by screw connectors mounted inside the housing.

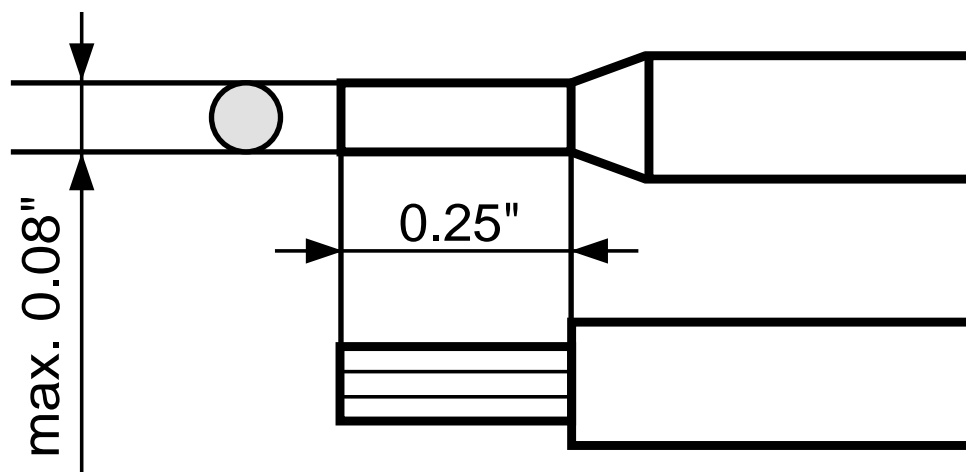
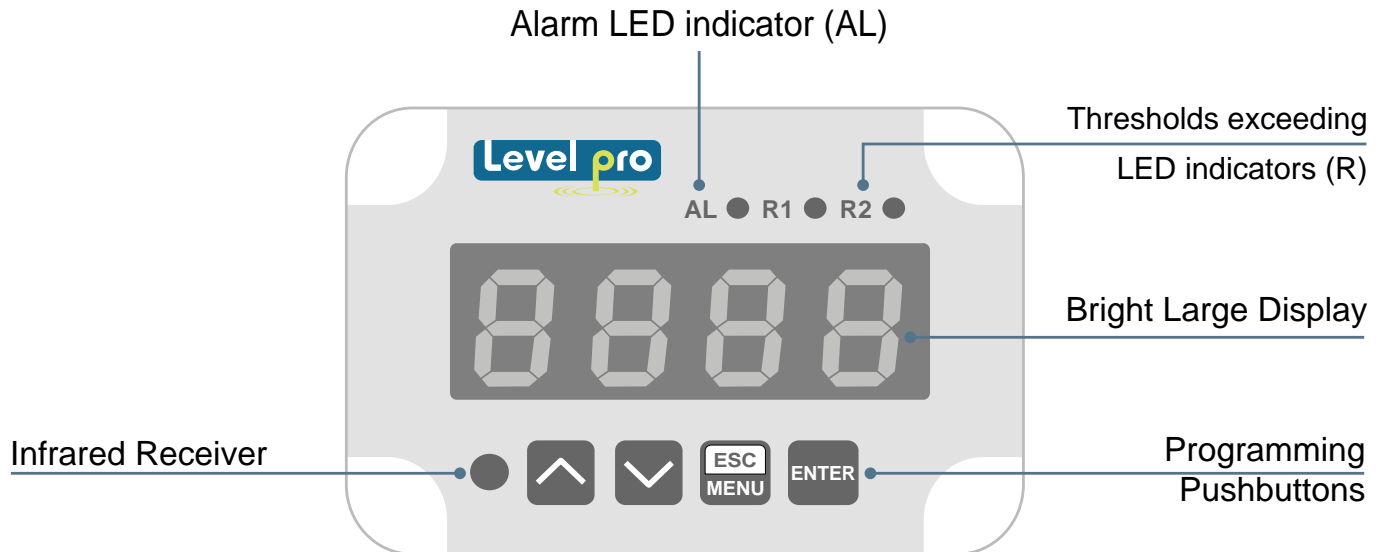

Figure 4.2. Method of cable insulation replacing and cable terminals

5. FRONT PANEL DESCRIPTION



Symbols and functions of Push Buttons :



Symbol used in the manual : [ESC/MENU]

Functions :

- Enter to main menu (press and hold for at least 2 sec.)
- Exit the current Screen and Enter to previous menu (or measure mode)
- Cancel the changes made in parameter being edited



Symbol used in the manual : [ENTER]

Functions :

- Start to edit the parameter
- Enter into the sub-menu,
- Confirmation of changes made in parameter being edited



Symbol used in the manual : [^] [v]

Functions :

- Change of the present menu,
- Modification of the parameter value,
- Change of the display mode.

LP 100 SERIES TECHNICAL DATA

INSTALLATION AND OPERATING MANUAL

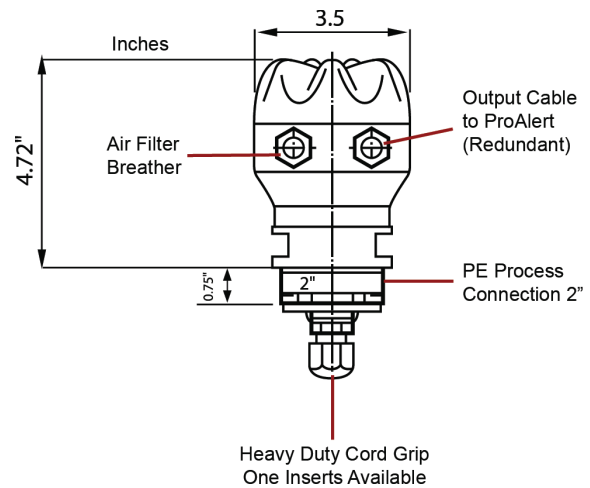
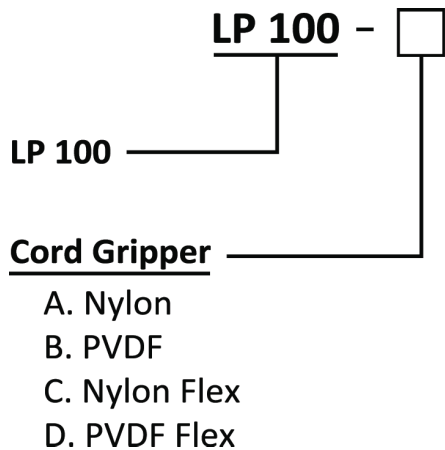
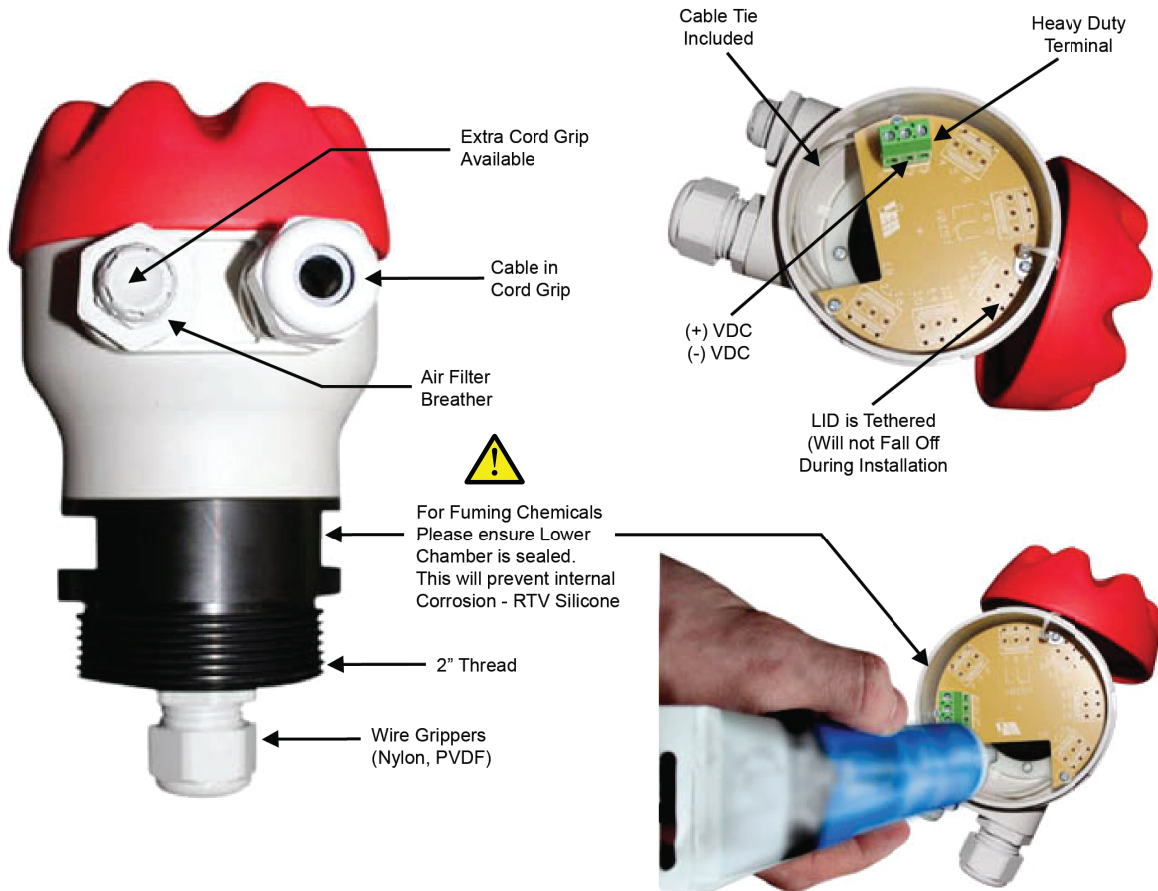

Contact Us for Assistance



For Fuming Chemicals please ensure Lower Chamber is sealed. This will prevent Internal Corrosion - RTV Silicone

MAINTENANCE

After final installation of the Levelpro transmitter and its companion display no routine maintenance is required. A periodic check of system calibration is suggested. Be sure to include a brief description of the problem plus any relevant application notes. Contact customer service to receive a return goods authorization number before shipping. Maintenance should consist of inspection to see that the transmitter is free from debris and not coated with any substance, which would prevent liquid from freely entering and leaving the transmitter. If this occurs, the transmitter should be cleaned.

6. PRINCIPLE OF OPERATION

When power is turned on the device ID and software version are showed on the display. The controller will then go into the measurement mode.

6.1. MEASUREMENT MODE

In the measure mode, the measurement results from the sensor are converted to programmed values which are then displayed on the LED screen. The measurement range equal to the nominal range is called : **normal measurement range**, and the measurement range equal to the extended nominal range is called: **permissible measurement range** (Figure 6.1, 6.2).

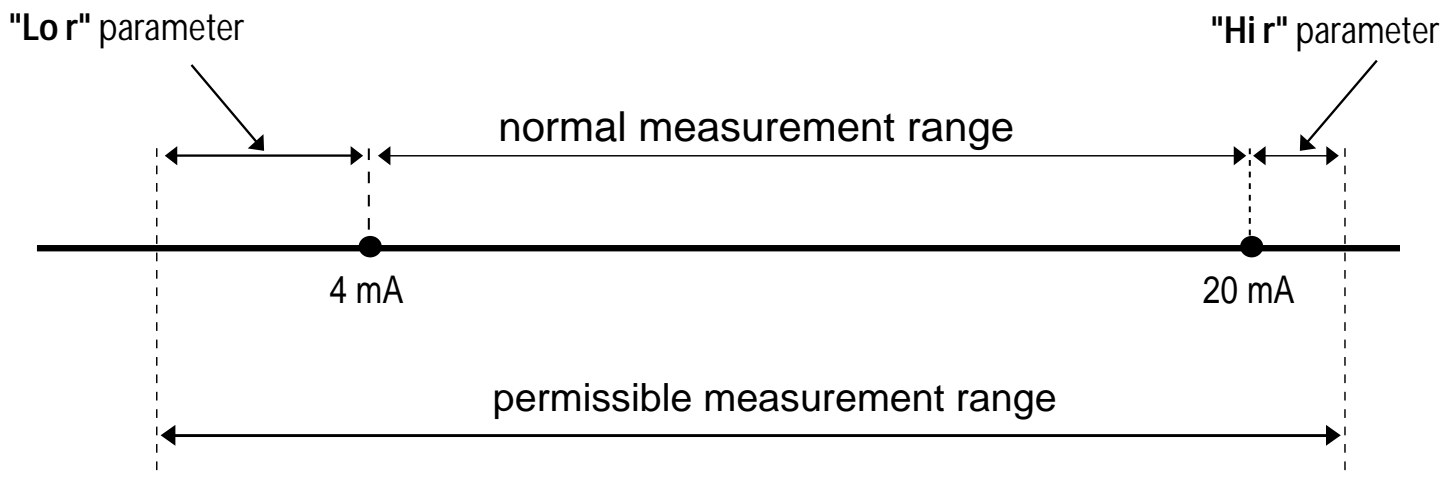

Figure 6.1. Definitions of measurement ranges in mode 4 - 20mA



If the measurement value does not exceed **permissible measurement range** but displayed value exceeds range $-999 \div 9999$, the warning "-Ov-" is displayed rather than the calculated Value.

In the measurement mode user can check main thresholds values. After pressing [**^**] or [**v**] button, name of the threshold (e.g. "rEL1") and the value will be displayed on the display in an alternating mode. If [**^**] or [**v**] is pressed within 5 sec, the next threshold will be displayed, Otherwise the device Will return to the measurement mode. If a **free access** is enabled (see description of "SECu" menu), user can change the value of particular threshold pressing button [**ENTER**] (see : **PARAMETERS EDITION**).

Input type, range of displaying values, characteristic of conversion, decimal point position and measure filtering ratio, are user configurable parameters. All accessible parameters can be changed by entering the menu (see: **DEVICE PROGRAMMING**). Use the local keyboard or the remote controller to do it. (Note: all parameters can be remotely changed via RS-485 interface).



Configuration of the device (via menu or RS-485 interface) Does not stop the measurements.

6.2. DETECTION OF THE PEAK VALUES

The **TruVu** controller is equipped with a peak detection function. It can detect the peak of the input signal and display the values. Presets connected with this function are placed in a **"HOLD"** menu (see description of **"HOLD"** menu). The detection of the peak can be done if the measured signal raises and drops in value at least equal to parameter **"PEA"**. Detected peaks are displayed during the time defined by parameter **"timE"**. If a new peak is detected while the current one is displayed, this new peak will be displayed and display time counter will be cleared (Figure 6.3). If no peaks are detected while time **"timE"** elapses, device starts to show the current value of input signal. Once again. If **"HdiS"="HOLD"** then setting parameter **"timE"=0.0** causes holding peak value until **[ESC]** button is pressed. If **"HdiS"="rEAL"** then value **"timE"=0.0** means no holding. Displaying peak value is signalized by flashing most right decimal point.

The relays/LEDs can be controlled depend on the current value of input signal or the peak value (see **"HOLD"** menu).

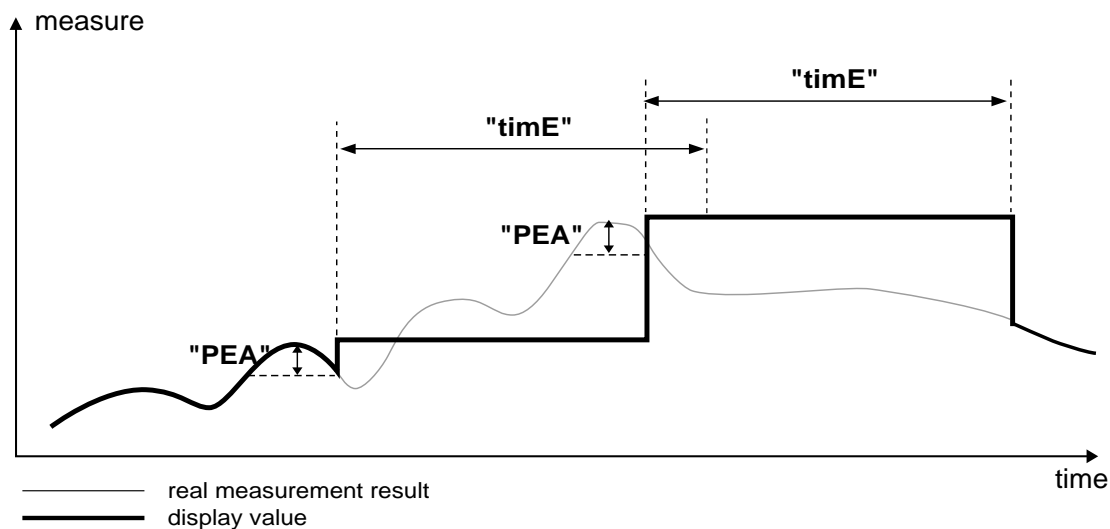

Figure 6.3. Process of peaks detection

6.3. CONTROL OF THE RELAY OUTPUTS

The control of the input (Fluid) (measured signal) is realized via relay outputs. Front panel LEDs named "R" indicates the state of particular relay output.



If device is not equipped with one or more relay outputs, menus refer to the relays being available, but apply to LED indicators only. In such case LEDs indicates exceeding of particular thresholds but no relay will be activated.

Modes of the control can be changed depend on the values of parameters **"SEtP"**, **"SEt2"**, **"HYSt"**, **"modE"**, **"t on"**, **"toFF"**, **"unit"** and **"AL"**. Depend on **"modE"** parameter, relays can be not used or controlled over one or two thresholds values.

If one threshold is used (Figure 6.4) the relay can be turned on (**"modE" = "on"**) or off (**"modE" = "oFF"**) when the input signal value is contained in **zone A**. If two thresholds are used (Figure 6.5) the relay will be turned on when value of input signal is contained in **zone A** (**"modE" = "in"**) or **zone B** (**"modE" = "out"**) and turned off if the signal is contained in the second one.

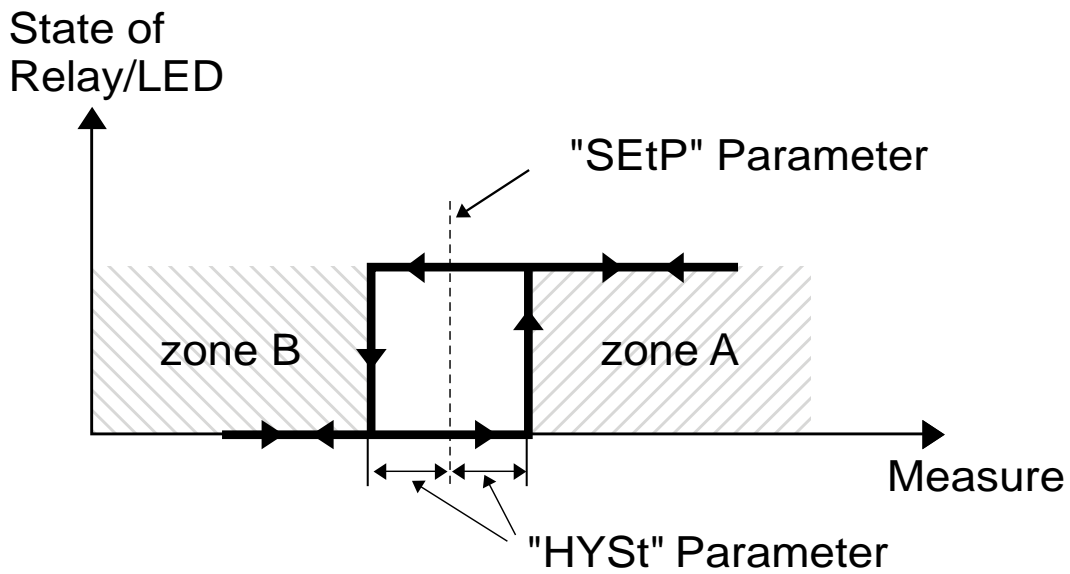

Figure 6.4. One threshold control of the Relay/LED outputs

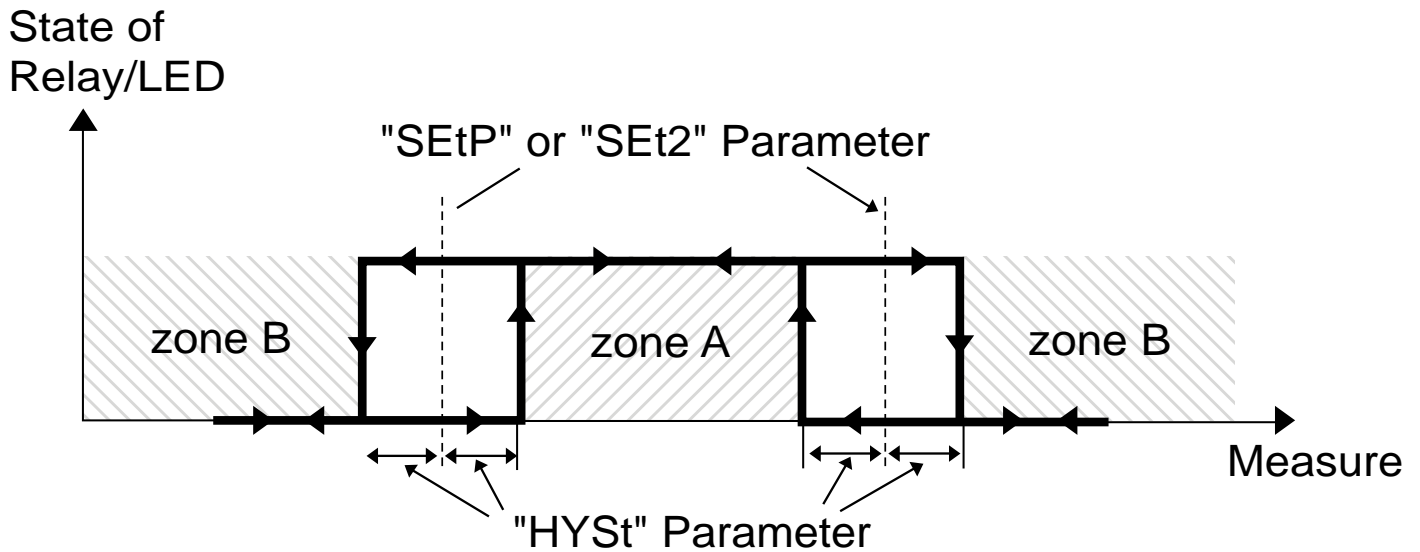

Figure 6.5. Two threshold control of the Relay/LED outputs



The relay outputs and LEDs (named R) can be controlled depend on both - the current value and the peak value (when peak detection is active) of the input signal.

7. DEVICE PROGRAMMING

The device menu allows user to set all the parameters connected to the operation of measurement input, control modes, critical situations behaviour, communication via RS-485 and access settings. The meaning of the particular parameters is described in paragraph **MENU DESCRIPTION**.

Some of the parameters can be accessed without entering menu (Quick View Mode). After pressing [**^**] or [**v**] button, name of the threshold (e.g. "rEL1") and the value will be displayed on the display in the alternating mode. If [**^**] or [**v**] is pressed within 5 sec, the next threshold will be displayed, else the device comes back to the measurement mode. If a free access is enabled (see description of "SECu" menu), user can change the value of particular threshold pressing button [**ENTER**] (see: **PARAMETERS EDITION**).



If particular parameter has been changed and confirmed in the Quick View Mode, the new value is displayed in the alternating mode with parameter name within a few seconds. Confirmed changes may be checked or user can switch viewed parameter by pressing [**^**] or [**v**] button.

7.1. PROGRAMMING MENU

To enter main menu (being in the measurement mode) operator must to Press and Hold for at least 2 sec. [**ESC/MENU**] button.

If the user Password is Defined (see parameter "Scod", menu "SECu"), the operator will have to enter the correct password before proceeding to the menu options. The Entering of the passwords is similar to the edition of numeric parameters (see: **PARAMETERS EDITION**), however presently editing the digit is shown only on the display, other digits are replaced by "-" sign. After entering of last digit of the password first menu position will be displayed (if the password is correct) or warning "Err" if password is incorrect.



Pay attention when device parameters are being changed. If it is possible, turn off controlled installation.

Functions of the buttons while sub-menu and parameters choice:



Selection of sub-menu or parameter for editing. Name of selected item (submenu or parameter) is displayed.



Operation of [**ENTER**] button depend on present menu position:

- if the name of some sub-menu is displayed - enter this sub-menu; name of the first parameter (or next level sub-menu) is displayed,
- if the name of some parameter is displayed - enter the edition of this parameter; present value of the parameter is displayed,



[**ESC/MENU**] button allow user to exit present menu level and goes to upper level menu (or measurement mode).



After about 1 min. of inactivity the, device will exit the menu mode and return to the measurement mode.

7.2. PARAMETERS EDITION

To start edition of any parameter user should select name of desired one using [^] [v] buttons and then press [ENTER].

7.2.1. Numeric parameters (digit change mode)

Numerical parameters are displayed as decimal numbers. The mode of the new value entered depends on chosen edit method (see parameter "Edit").

In mode "by digit" ("Edit"="dig") pressing one of the keys [^] or [v] causes change of current position (flashing digit) or the sign (+/-). Short pressing of the [ENTER] button causes change of the position (digit).

Press [ENTER] for at least 2 seconds to accept the changes, after that question "Set?" is displayed, and user must to confirm (or cancel) the changes. To conform changes (and store it in EEPROM) press [ENTER] button shortly after "Set?" is displayed. To cancel the changes press [ESC] button shortly after "Set?" is displayed. After that device returns to the menu.

7.2.2. Numeric parameters (slide change mode)

In "slide change" mode ("Edit"="Slid"), buttons [^] and [v] has different functions.

To increase edited value press (or press and hold) [^] button only, the increasing becomes faster as long as button [^] is pressed. To slow down the button [v] can be used. If [v] is pressed shortly (and button [^] is still pressed), increasing will slow down for a moment only, if [v] is pressed and held while button [^] is still pressed the quick digit change will be kept on lower speed.

To decrease edited value press (or press and hold) [v] button only. The decreasing becomes faster as long as button [v] is pressed. To slow down the decrease, button [^] can be used. If [^] is pressed shortly (and button [v] is still pressed), decreasing slow down for a moment only, if [^] is pressed and held while button [v] is still pressed the Speed will slow down and will be kept on lower speed.

Press [ENTER] at least 2 seconds to accept the changes, after that question "Set?" is displayed, the user must confirm (or cancel) the changes. To confirm the changes (and store them in EEPROM) press the [ENTER] button shortly after "Set?" is displayed. To cancel the changes press [ESC] button shortly after "Set?" is displayed. After that device returns to the menu.

7.2.3. Switch parameters ("LIST" type)

Switch parameters can be described as a sets of values (a lists) out of which only one of the options available on the list can be selected for the given parameter. Options of switching parameter are selected using [^], [v] keys. Short (Quick) pressing of [ENTER] results in the display the user to acknowledge the question ("Set?"). If key [ENTER] is pressed again, the changes are accepted, stored in EEPROM end the edition process finished. Pressing the key [ESC] after "Set?" causes cancelling of changes made and display returns to the main menu.

Functions of buttons when editing numeric and switching parameters :



While editing numeric parameter:

- Change of current (flashing) digit
- Slide change of value (acceleration, deceleration, direction change)

While editing switch parameter - selection of switch parameter.



If numerical parameter is being edited, a short quick pressing of **[ENTER]** button will change edited position. A long press of **[ENTER]** button (at least 2 sec.) the display to request **"SEt?"** confirm, which allow user to make sure the change of the parameter value is correct. If switch parameter is being edited, a short press of **[ENTER]** button causes the display a **"SEt?"** confirmation. When **[ENTER]** button is pressed again (while **"SEt?"** is displayed) the new value of the parameter is stored in EEPROM memory.



Pressing this button the operator can cancel the changes done up to now (if they were not approved by **[ENTER]** button after the **"SEt?"** request) and will return to the main menu. menu.

7.3. MENU DESCRIPTION

"- - - -"

Password checking. If the password is different from **"0000"**, then the number (password must be entered every to enter main menu) every enter to main menu follows the entering of password. If entered password is correct then first menu position will be displayed other wise the warning **"Err"**, and unit returns to measurement mode.



Due to problem with direct displaying of **"m"** and **"K"** letters, they are exchanged with special signs **"ñ"** for **"m"** and **"†"** for **"K"** respectively. However, the user manual letters **"m"** and **"K"** are used to make it more readable (example: **"modE"**, **"tc K"**).

7.3.1. "rEL1" menu

This menu allows to configure the operation mode of relays and LEDs marked **"R"** (e.g. **"R1"**).

If there are few relay outputs available, then every output has its own configuration menu (e.g. menu **"rEL2"** for relay (LED) **"R2"**). Principle of the relays operation is described in paragraph **CONTROL OF THE RELAY OUTPUTS**.

- The relay outputs and LEDs (named **R**) can be controlled depend on both – the current value and the peak value (when peak detection is active) of the input signal.
- If device is not equipped with one or more relay outputs, menus refer to this relays are available, but apply to LED indicators only. In such case LEDs indicates exceeding of particular thresholds.

"SEtP"

first threshold of the relay (range -999 ÷ 9999). Negative values can be input by selecting a **"-"** sign on first digit (to change value use **[^]** and **[v]** buttons). **Threshold is the median value of relay hysteresis.**

"SEt2"	second threshold of the relay (range $-999 \div 9999$). Negative values can be input by selecting a "-" sign on first digit (to change value use [^] and [v] buttons). This threshold is accessible when "modE" parameter is set to "in" or "out" value. Threshold is the median value of relay hysteresis.
"HYSt"	hysteresis of relay (range $0 \div 999$). Full hysteresis of the relay is equal to $2x$ "HYSt" parameter. The relay state can change when an input signal is out of threshold hysteresis to threshold+hysteresis zone.

Presented parameters should be set to ensure that "SEtP" + "HYSt", "SEt2" + "HYSt", "SEtP" - "HYSt" or "SEt2" - "HYSt" does not exceed the measure range. Additionally, in the two threshold mode ("modE"= "in" or "out"), the hysteresis for both thresholds must not overlap one another (in other case relay will not change state).

"modE" - relay operation mode :

"noAC"	the relay is not active (permanently turned off)
"on"	one threshold mode, the relay is turned ON when input signal exceeds the SEtP + HYSt value, and is turned off when the input signal became over than SEtP – HYSt ,
"oFF"	one threshold mode, the relay is turned OFF when input signal exceeds SEtP + HYSt value, and is turned on when the input signal became lower than SEtP – HYSt ,
"in"	two threshold mode, the relay is turned ON when the input signal is greater than " lower threshold + HYSt " and below than " bigger threshold HYSt ", and turned off when the input signal is contained within the second zone. The hanger threshold equals the hanger one of "SEtP" and "SEt2" thresholds, the smalle threshold " means the smaller one of "SEtP" and "SEt2" thresholds.
"out"	two threshold mode, relay is turned ON when the input value is greater than " bigger threshold + HYSt " and lower than " smaller threshold – HYSt "; and turns on when the input signal is contained in the second zone. The hanger threshold means hanger one of "SEtP" and "SEt2" thresholds, the Smaller threshold " means Smaller one of "SEtP" and "SEt2" thresholds.
"modb"	the relay is controlled via RS-485 interface, independently on the input signal.



- LEDs lights up when relays are closed, independently of relays' mode.
- When the power supply fails, the unit does not store relays state selected by RS- 485 interface.

"t on"	turn on the delay time, the relay is turned on with delay equal "t on" if the input value exceeds the appropriate border value (defined with threshold and hysteresis), "t on" time. "t on" range 0 ÷ 99.9, defined with 0.1 sec. resolution. Unit of this parameter is set by "unit" parameter.
"toFF"	turn off delay time, the relay is turned off with delay equal "toFF" if the input value exceeds appropriate border value (defined with threshold and hysteresis), "toFF" time. "toFF" range 0 ÷ 99.9, defined with 0.1 sec. resolution. Unit of this parameter is set by "unit" parameter.



If time when the input signal exceeds some border value and is shorter than the **"t on"** or **"toFF"** time, the relay does not change its state (see paragraph: **CONTROL OF THE RELAY OUTPUTS**).

"unit"	unit of time for "t on" i "toFF" parameters. The unit be set to one of two values: <table border="1" data-bbox="467 877 1149 1003"> <tr> <td data-bbox="474 877 727 940">"min"</td> <td data-bbox="727 877 1143 940">minutes</td> </tr> <tr> <td data-bbox="474 940 727 1003">"SEC"</td> <td data-bbox="727 940 1143 1003">seconds</td> </tr> </table>	"min"	minutes	"SEC"	seconds		
"min"	minutes						
"SEC"	seconds						
"AL"	this parameter defines the relay reaction when some critical situations occurs: <table border="1" data-bbox="467 1115 1149 1297"> <tr> <td data-bbox="474 1115 727 1178">"noCH"</td> <td data-bbox="727 1115 1143 1178">relay do not change state,</td> </tr> <tr> <td data-bbox="474 1178 727 1241">"on"</td> <td data-bbox="727 1178 1143 1241">relay will be turned on,</td> </tr> <tr> <td data-bbox="474 1241 727 1297">"oFF"</td> <td data-bbox="727 1241 1143 1297">relay will be turned off.</td> </tr> </table> <p>If parameter "modE" is set to "on" , "oFF", "in" or "Out" the "critical situation" means that the allowable measurement range is exceeded. If parameter "modE" is set to "modb", the "critical situation" means the communication delay (when no data is received) is longer than "mbtO" parameter (see description: "rS" menu).</p>	"noCH"	relay do not change state,	"on"	relay will be turned on,	"oFF"	relay will be turned off.
"noCH"	relay do not change state,						
"on"	relay will be turned on,						
"oFF"	relay will be turned off.						

ALARM LED

The ALARM LED (**AL**) is turned on when input signal is out of the permissible input range. See parameters: **"tyPE"**, **"Lo r"** and **"Hi r"** in paragraph **"InPt"** menu.

OVER-CURRENT PROTECTION

The current input of the device is equipped with over-current protection circuit. This circuit protects the standard resistor against damage. Maximum input current is set to 40mA (typical). When temperature of the standard resistor falls, the protection circuit will turn on automatically, and the device will measure the input current again. Due to thermal phenomenon in the standard resistor, precision of the measurement may be lower until to the standard resistor temperature will falls to the environment temperature.

7.3.2. "inPt" menu

This menu presets the measurement input:

"tYPE"	<p>- type of the input / sensor. This parameter can be set to values:</p> <p>"0-20", "4-20" - current inputs. "0-10", "2-10", "0-5", "1-5" - voltage inputs.</p> <p>Displayed values are defined by parameters "Lo C", "Hi C" (or by user defined characteristic points) and parameter "Pnt".</p>
"CHAR"	<p>- this option presets type of the conversion characteristic, and can be set to:</p> <p>"Lin" - linear "Sqr" - square "Sqrt" - square root</p> <p>} When one of those characteristics is chosen display range is defined by "Lo C" and "Hi C".</p> <p>"USER" - user defined characteristic. Maximal length 20 points. Every point is defined by user. Adding, Editing and Deleting of points is done by options „AddP“, „EdtP“, „dELP“ („InPt“ menu) respectively.</p> <p>"tn v" - volume characteristics of a cylindrical tank in the vertical position, determined by parameters: „t h1“, „t h2“, „t h3“, „t d“, „t Sn“, „t Sh“ in „InPt“ menu (see below for details of the parameters),</p> <p>"n h" - volume characteristics of a cylindrical tank in the horizontal position, determined by parameters: „t h1“, „t h2“, „t h3“, „t d“, „t Sn“, „t Sh“ in „InPt“ menu (see below for details of the parameters).</p>

 If user defined characteristic is selected, and if number of defined points is lower than 2 then warning "Errc" is displayed in measurement mode.

The process of displayed result calculation is described in details in **DISPLAY VALUES CALCULATION** paragraph.

"FiLt"	<p>- this parameter sets filtration rate. It can be set to values from 0 (no filtration) to 5 (strongest filtration – time window about 2 sec).</p>
"Pnt"	<p>- decimal point position. It can be set to one of: "0", "0.0", "0.00", "0.000"</p> <p>Decimal point position is changed by [^], [v] buttons.</p>
"Lo C" "Hi C"	<p>These parameters describe the values displayed for minimum and maximum input signal value for selected input type. For example, if input type is set to 4-20 mA "LoC" parameter defines the value displayed when input current is equal 4 mA, and "Hi C" parameter defines the value displayed for 20 mA of input current. Available range for these parameters: -999 ÷ 9999. Negative values can be set by entering '-' sign on the first position (by use of [^], [v] buttons).</p>

 If volume characteristics of a cylindrical tank is selected (parameter "CHAR" = "tn v" or "CHAR" = "n h") the parameters „Lo C" and „Hi C" are not available.

„t h1“, „t h2“, „t h3“, „t d“ - the parameters defining shape of cylindrical tank (Figure 7.1 and Figure 7.2).

a) for the cylindrical tank in the vertical position:

„t h1“	- the height of the bottom part of a tank (in the elliptic paraboloid shape), this parameter has the fixed precision - 2-decimal point,
„t h2“	- the height of the middle part of a tank in the cylindrical shape, this parameter has the fixed precision - 2-decimal point,
„t h3“	- the height of the top part of a tank (in the elliptic paraboloid shape), this parameter has the fixed precision - 2-decimal point,
„t d“	- the diameter of the middle part of a tank, this parameter has the fixed precision - 2-decimal point,

b) for the cylindrical tank in the horizontal position:

„t h1“	- the length of the left bottom of a tank (in the elliptic paraboloid shape), this parameter has the fixed precision - 2-decimal point,
„t h2“	- the length of the middle part of a tank in the cylindrical shape, this parameter has the fixed precision - 2-decimal point,
„t h3“	- the length of the right bottom of a tank (in the elliptic paraboloid shape), this parameter has the fixed precision - 2-decimal point,
„t d“	- the diameter of the middle part of a tank, this parameter has the fixed precision - 2-decimal point,

„t Sn“, „t Sh“ - parameters defining the length and position of the sensor used to measure level of liquids, gases or solids in the tank (Figure 7.1, 7.2).

„t Sn“	- distance between end of the sensor and bottom of the tank, this parameter has the fixed precision 2-decimal point but the unit is 100 times smaller than „t Sh“ (see Info below),
„t Sh“	- the measuring range, this parameter has the fixed precision - 2-decimal point.



- The unit value of „t Sn“ parameter is 100-fold less than the unit value of other parameters defining cylindrical tank, i.e. if we set value 10.00 in „t Sh“ parameter and set value 08.00 in „t Sn“ parameter this mean that value of „t Sn“ parameter is real has 00.08 value in preserved unit of the „t Sh“ parameter.



- If we set parameters of tank in [m] unit ("t Sn" parameter takes [cm] unit respectively, see above), than displays the result the volume of the tank in [m3] unit, if we set parameters of tank in [cm] unit ("t Sn" parameter takes [mm] unit respectively, see above), than displays the result the volume of the tank in [cm3] unit.
- "t Sh" parameter may be greater than height (for vertical position) or diameter (for horizontal position) of the tank, which means that the total volume of the tank can be achieved by eg. such middle-current range,
- If the measurement value does not exceed permissible measurement range but displayed value exceeds range of 9999 than you can move to the right position of the decimal point if it is still possible (see parameter Menu->"inPt"->"Pnt").
- If in the volume characteristics of a cylindrical tank is exceeded the value of the volume of the tank sets by parameters available in menu "inPt" instead of the calculated result will be display warning "-Hi-".

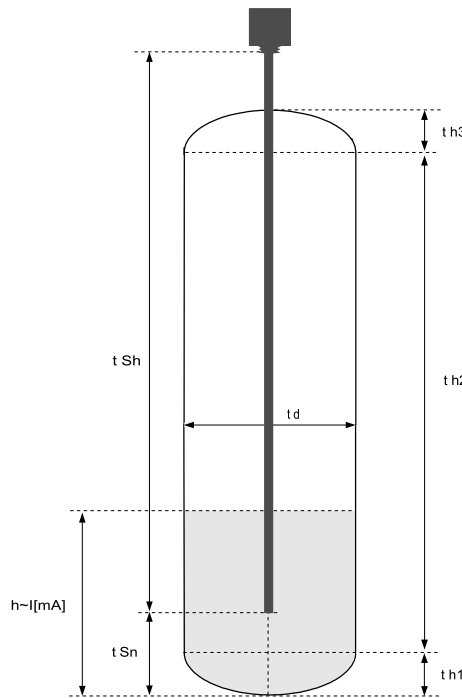

Figure 7.1 Parameters of cylindrical tank in vertical position.

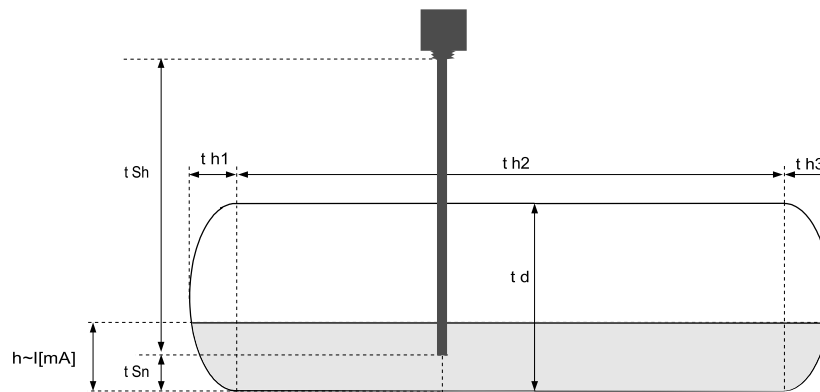

Figure 7.2 Parameters of cylindrical tank in horizontal position.



If user defined characteristic is selected (parameter "CHAR" = "USER") the parameters „Lo C" and „Hi C" are not available for modification, due to their values are calculated from defined characteristic.

"AddP"	- this menu allow user to add single point to the user defined characteristic. After selection of this option device waits for „X" and „Y" coordinates of new point. Modification of the coordinates is done accordingly to numerical parameters edition. Coordinate „X" defines the percentage ratio of input current to selected current range. The „X" range: -99,9 ÷ 199,9. Coordinate „Y" defines displayed value for particular „X" value. The „Y" value can be changed in range: -999 ÷ 9999, decimal point position depend on „Pnt" parameter (menu "inPt").
--------	--

- User can not enter two points with the same value of „X" coordinate. If user trays to do it, "Err" warning is displayed. To modify any defined point use "EdtP" option.



- To distinguish „X" and „Y" coordinates, if „X" coordinate is displayed an additional decimal point on utmost right position is displayed.
- If user defined characteristic is selected, and if number of defined points is lower than 2 then warning "Errc" is displayed in measurement mode.

"dELP"	- this option allows user to delete any of the points of the user defined characteristic. After selection current number of points of the user defined characteristic is displayed for about approx. 1.5 sec. After that device waits for selection of point being deleted (by [^], [v] buttons). The short pressing of [ENTER] button causes by switching between X and Y value of the displayed point. The long press (press and hold at least 2 sec) of [ENTER] button causes by displaying „dEL?" ask. If [ENTER] button is pressed again, current point is deleted and new updated number of points of the user defined characteristic is displayed.
"EdtP"	- this option allows user to modify of particular point of the user defined characteristic. After selection current number of points of the user defined characteristic is displayed for about approx. 1.5 sec. After that device waits for selection of point being edited (by [^], [v] buttons). The short pressing of [ENTER] button causes by switching between X and Y value of the displayed point. The long press (press and hold at least 2 sec) of [ENTER] button causes by entering to edit the selected coordinate of the point. Modification of the coordinates is done accordingly to numerical parameters edition.



"AddP", "dELP" and "EdtP" options are available only if the user defined characteristic is used (it means when parameter "CHAR" = "USER").

"Lo r" "Hi r"	- these parameters define the expansion of nominal range in percent. They determine the permissible range of input signal (Figure 7.3). The permissible range allow user to exceed the nominal range of input signal. If input value is contained in the permissible range a proper result is displayed. If input signal exceeds this range (defined by "Lo r" and "Hi r"), "-Lo-" or "- Hi-" warning is displayed depend on input signal value.
------------------	--

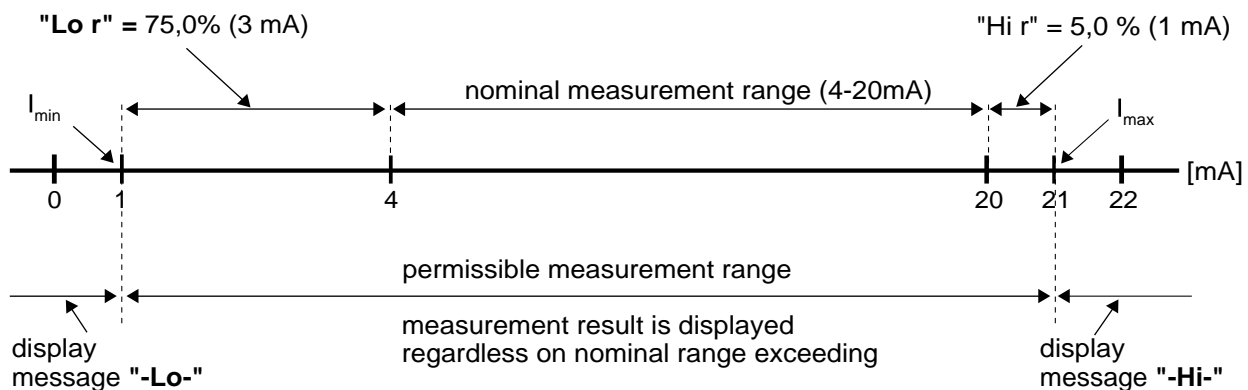

Figure 7.3 Example of definition of permissible range of input signal - "Lo r" and "Hi r" parameters ("4-20" mode)

The "Lo r" parameter is important if input is set to "4-20", "1-5" or "2-10" mode only, and determines lower border of the permissible range. If input is set to "0-20", "0-5" or "0-10" mode then lower border of the permissible range is always 0.

For example if input is set to "4-20" mode, then lower border is calculated due to expression: $I_{min} = 4 \text{ mA} - 4 \text{ mA} \times \text{"Lo r"} \%$. The "Lo r" value can be set from 0 to 99.9%.

Parameter "Hi r" determines the upper border of the permissible range accordingly to the expression (for all modes).

For example if input is set to "4-20" mode, then upper border is calculated due to expression: $I_{max} = 20 \text{ mA} + 20 \text{ mA} \times \text{"Hi r"} \%$.

The value of "Hi r" can be set from 0 to 19.9%

In example no 1 of the **DISPLAY VALUES CALCULATION** paragraph the procedure of the permissible input range determining is presented in details.



If the measurement value does not exceed **permissible measurement range** but displayed value exceeds range -999 ÷ 9999, the warning "-Ov-" is displayed rather than the calculated result.

7.3.3. "OutP" menu

This menu contains parameters of analogue output control. Menu is available if the device is equipped with analogue output.



Analogue output can be controlled depend on both present measured value and peak value (if peak detection is enabled).

"Omod" - analogue output mode. Depending on version of the device there are following options:

For active current output:

- "oFF" - current output disabled,
- "0-20" - current output enabled with 0 ÷ 20 mA mode,
- "4-20" - current output enabled with 4 ÷ 20 mA mode,
- "modb" - current output controlled via RS-485 interface.

For passive current output:

- "oFF" - current output disabled,
- "4-20" - current output enabled with 4 ÷ 20 mA mode,
- "modb" - current output controlled via RS-485 interface.

For active voltage output:

- "oFF" - voltage output disabled,
- "0-5" - voltage output enabled with 0 ÷ 5V mode,
- "1-5" - voltage output enabled with 1 ÷ 5V mode,
- "0-10" - voltage output enabled with 0 ÷ 10V mode,
- "2-10" - voltage output enabled with 2 ÷ 10 V mode,
- "modb" - voltage output controlled via RS-485 interface.

"OutL"	- this parameter determines the input value for which the output signal is minimal (depend of output mode „Omod“).
"OutH"	- this parameter determines the input value for which the output signal is maximal (depend of output mode „Omod“).

The analogue output value is calculated due to formula given below:

$$Out = \frac{W - "OutL"}{"OutH" - "OutL"} \times (B - A) + A$$

- where: **W** – displayed value,
Out – analogue output value,
B – higher range limit (20mA / 5V / 10V),
A – lower range limit (0mA / 4mA / 0V / 1V / 2v),



"OutL" parameter can be greater than "OutH". In this case the conversion characteristic is reversed, it means that if input value raises the output value falls.

"Lo r", "Hi r" - these parameters define the output value range. If calculated output value Out exceeds defined range then analogue output generates signal equal to upper or lower border of the defined range. These parameters define the percentage extension of nominal analogue range (with 0,1% resolution).

Parameter **"Lo r"** defines lower border of the range due to formula:

Out_{min} = A - (A × "Lo r" %), where:

A – lower signal value range limit.

This parameter can be set from 0 to 99.9% (for active current output and active voltage output) or from 0 to 29.9% (for passive current output).

Parameter **"Hi r"** defines higher border of the range due to formula:

Out_{max} = B + (B × "Hi r" %), where:

B – higher signal value range limit.

This parameter can be set from 0 to 19.9% (for active and passive current output) or from 0 to 9.9% (for active voltage output).

In example on page 51 of the **DISPLAY VALUES CALCULATION** paragraph the procedure of the analogue outputs determining is presented in details.

"AL" - this parameter determines the behaviour of analogue output if any critical situation occurs. According to version of the device, this parameter can be set:

For active current output:

- "noCH"** - current will not change,
- "22.1"** - current will be set to 22.1 mA,
- "3.4"** - current will be set to 3.4 mA,
- "0.0"** - current will be set to 0 mA.

For passive current output:

- "noCH"** - current will not change,
- "22.1"** - current will be set to 22.1 mA,
- "3.4"** - current will be set to 3.4 mA,

For active voltage output:

- "noCH"** - voltage will not change,
- "11.0"** - voltage will be set to 11 V,
- "5.5"** - voltage will be set to 5.5 V,
- "1.2"** - voltage will be set to 1.2 V.
- "0.6"** - voltage will be set to 0.6 V,
- "0.0"** - voltage will be set to 0 V.

When the critical situation goes, the output signal will be set to value calculated due to formulas given above.

The "one-use password" can be used **ONE TIME ONLY**, it is impossible to use it again! The "one-use password" can be restored by Service Division only.

See previous page

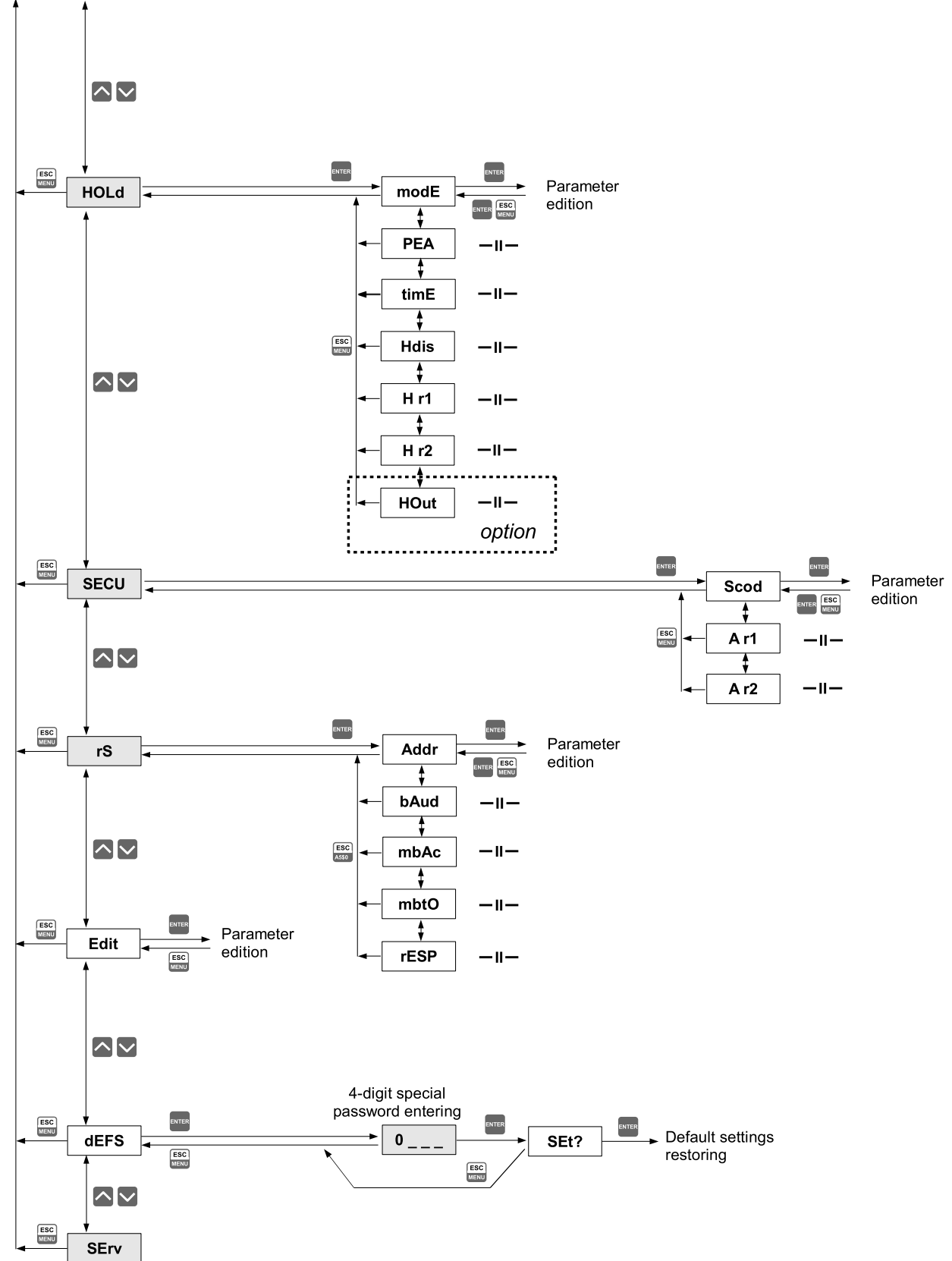

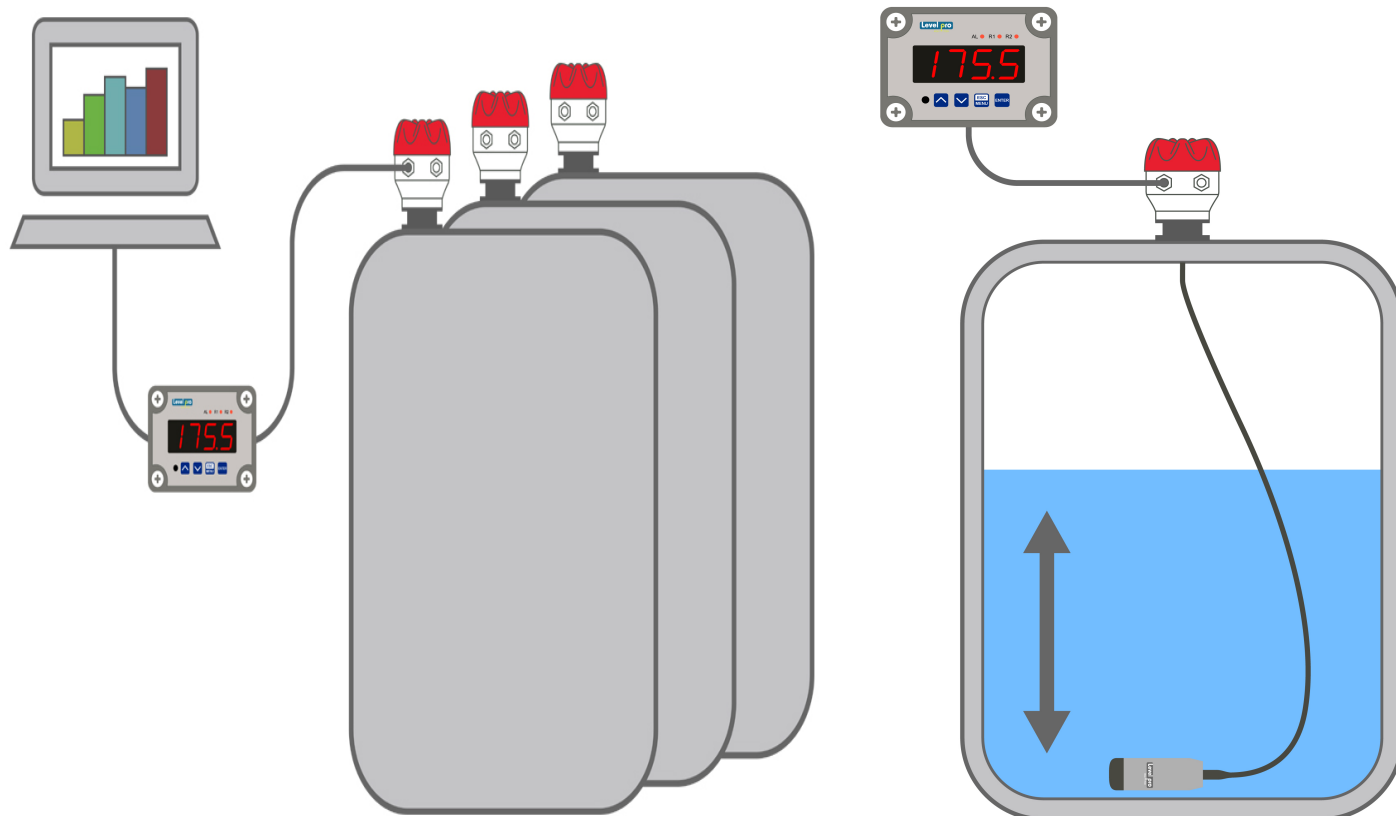

Specification may be modified without notice in advance.

For complete product documentation, video training, and technical support, go to

www.iconprocon.com or contact us at 905 469 9283

(Please make sure you have the Part and Serial number available)